

SINGLE SERVING AUTOMATIC POD MACHINE FRESH CUP 4

NEWCO ENTERPRISES INC,
3650 NEW TOWN BLVD SAINT CHARLES, MO 63301
1-800-325-7867



FEATURES/ SPECIFICATIONS

- AUTOMATIC POD REMOVAL
- FLOWMETER
- UP TO 20 OZ TRAVEL MUG
- LARGE POD WASTE TRAY / PASS THROUGH OPTION
- ADJUSTABLE DRINK STRENGTH
- ADJUSTABLE DRINK VOLUME
- 1 GALLON WATER TANK CAPACITY

NEWCO CONTACT INFORMATION

ADDRESS

NEWCO ENTERPRISES INC,
3650 NEW TOWN BLVD SAINT CHARLES, MO 63301

CUSTOMER SERVICE PHONE

1-800-325-7867

TECHNICAL SERVICE PHONE

1-800-556-3926

FAX

1-636-925-0029

WEBSITE

newcocooffee.com

CUSTOMER SERVICE AND SALES EMAIL

sales@newcocooffee.com

MAINTENANCE INFORMATION

Machine Model _____

Company Information and Phone Number

TABLE OF CONTENTS

NEWCO PRODUCT WARRANTY----- 4

SPECIFICATIONS----- 5

MACHINE SET-UP----- 7

MACHINE PROGRAMMING----- 8

MACHINE OPERATION----- 14

SERVICING THE MACHINE

 SIDE PANEL REMOVAL----- 15

 REMOVING THE BREW MECHANISM----- 16

 DRAINING THE HOT WATER TANK----- 17

 TANK REMOVAL & ACCESS AREAS----- 18

 ERROR MESSAGES----- 19

INSIDE YOUR MACHINE

 POD BREWING MECHANISM----- 20

 TANK ASSEMBLY----- 21

 ELECTRICAL COMPONENTS----- 22

 WIRING DIAGRAM ----- 23

WARRANTY

This warranty supersedes all other previous warranties that are currently in manuals.

Newco warrants equipment manufactured by it for 1 year parts and labor. Accessories, Dispensers, and Display Tablets - 1 Year parts only. Electronic Circuit and Control Boards- 3 years parts, 1 year labor. Equipment manufactured by others and distributed by Newco- please see original equipment manufacturers warranty, Newco will follow.

These warranty periods run from the date of sale Newco warrants that the equipment manufactured by it will be commercially free of defects in material and workmanship existing at the time of manufacture and appearing within the applicable warranty period. This warranty does not apply to any equipment, component or part that was not manufactured by Newco or that, in Newco's judgment, has been affected by misuse, neglect, alteration, improper installation or operation, relocation or reinstallation, improper maintenance or repair, incorrect voltage applied to the unit at any time, damage or casualty. This warranty does not apply to any equipment failures related to poor water quality, excessive lime and chlorine and non-periodic cleaning and descaling. Warranty is null and void if muriatic or any other form of hydrochloric acid is used for cleaning or deliming. In addition, this warranty does not apply to replacement of items subject to normal use including but not limited to user replaceable parts such as faucet seat cups, sight gauge tubes, washers, o-rings, tubing, seals, and gaskets.

This warranty is conditioned on the Buyer 1) giving Newco prompt notice of any claim to be made under this warranty by telephone at (800) 556-3926 or by writing to **3650 New Town Blvd, Saint Charles, MO 63301**; 2) if requested by Newco, shipping the defective equipment prepaid to an authorized Newco service location; and 3) receiving prior authorization from Newco that the defective equipment is under warranty.

THE FOREGOING WARRANTY IS EXCLUSIVE AND IS IN LIEU OF ANY OTHER WARRANTY, WRITTEN OR ORAL, EXPRESS OR IMPLIED, INCLUDING, BUT NOT LIMITED TO, ANY IMPLIED WARRANTY OF EITHER MERCHANTABILITY OR FITNESS FOR A PARTICULAR PURPOSE. The agents, dealers or employees of Newco are not authorized to make modifications to this warranty or to make additional warranties that are binding on Newco. Accordingly, statements by such individuals, whether oral or written, do not constitute warranties and should not be relied upon.

If Newco determines in its sole discretion that the equipment does not conform to the warranty, Newco, at its exclusive option while the equipment is under warranty, shall either 1) provide at no charge replacement parts and/or labor (during the applicable parts and labor warranty periods specified above) to repair the defective components, provided that this repair is done by a Newco Authorized Service Representative; or 2) shall replace the equipment or refund the purchase price for the equipment.

THE BUYER'S REMEDY AGAINST NEWCO FOR THE BREACH OF ANY OBLIGATION ARISING OUT OF THE SALE OF THIS EQUIPMENT, WHETHER DERIVED FROM WARRANTY OR OTHERWISE, SHALL BE LIMITED, AT NEWCO'S SOLE OPTION AS SPECIFIED HEREIN, TO REPAIR, REPLACEMENT OR REFUND.

In no event shall Newco be liable for any other damage or loss, including, but not limited to, lost profits, lost sales, loss of use of equipment, claims of Buyer's customers, cost of capital, cost of down time, cost of substitute equipment, facilities, or services, or any other special, incidental or consequential damages.

WARNING: Read and follow installation instructions before plugging or wiring in machine to electrical circuit. Warranty will be void if machine is connected to any voltage other than that specified on the serial tag. Machine must be plugged into a grounded outlet.

SPECIFICATIONS

TANK WATTAGES

US 1700W 120V

CANADA 1400W 120V

TANK CAPACITY

1 US GALLON

DRIP TRAY CAPACITY

8 OUNCES

POD WASTE TRAY CAPACITY

50 PODS*

UP TO 20 OZ CUP SIZE

SHIPPING WT

APPROX 35 LBS

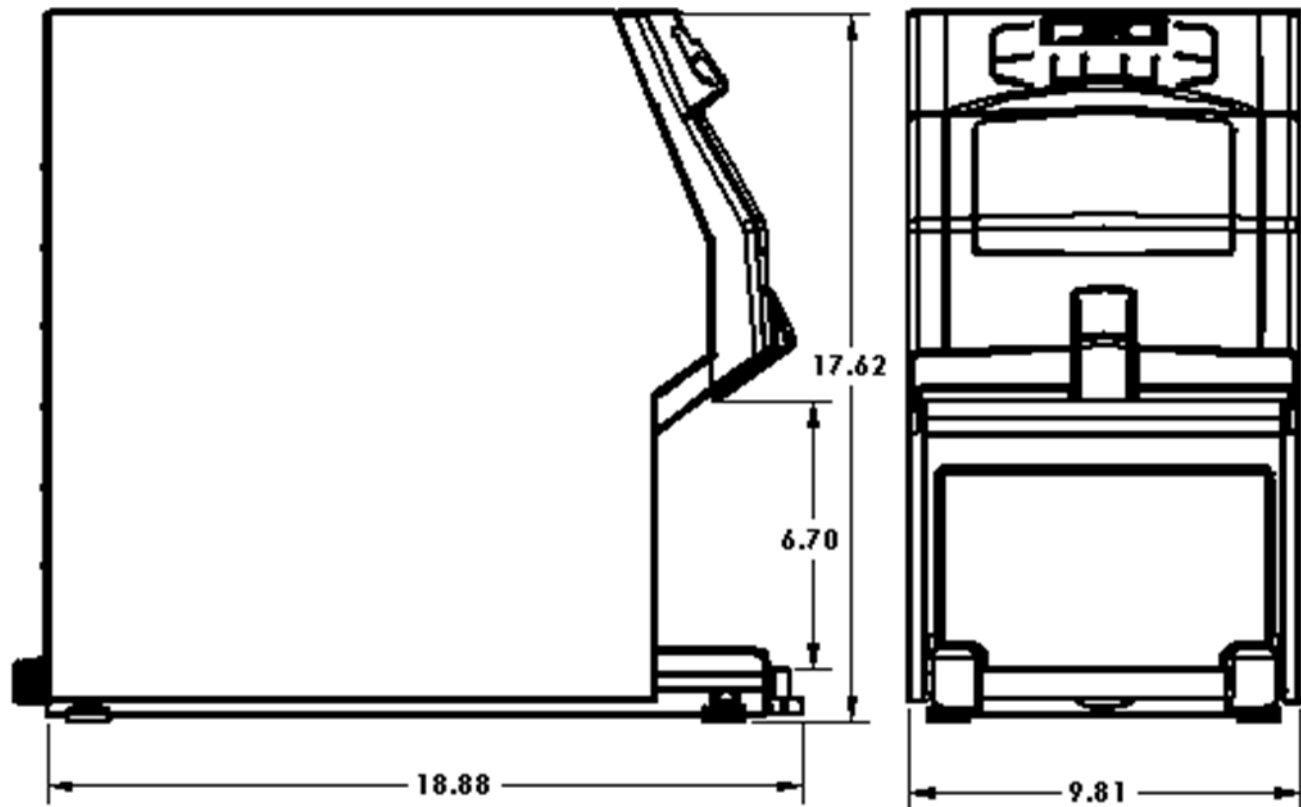

*Depending on pod size

USE WASTE TRAY PN 782183 FOR PASS THROUGH USE

Rear of machine

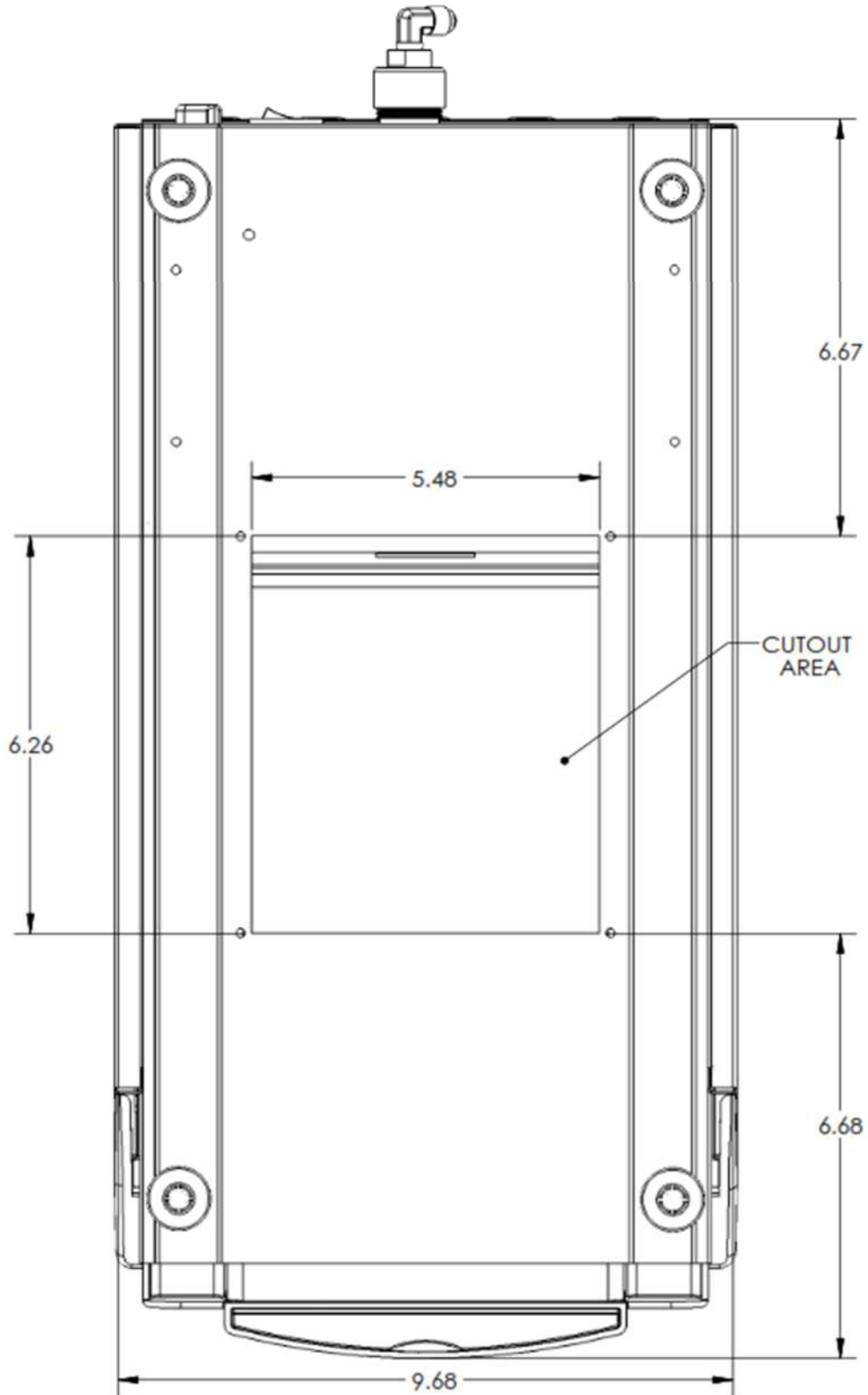

Front of machine

MACHINE SET-UP

NOTE: The FRESH CUP machine weighs approximately 35 LBS. Use CAUTION when unpacking and lifting machine. LIFT MACHINE FROM MACHINE BOTTOM ONLY. DO NOT MOVE MACHINE UNLESS THE HOT WATER TANK IS DRAINED AND EMPTY.

PLUMBER'S INSTALLATION INSTRUCTIONS

1. Brewer must be installed to comply with all applicable federal, state, and local plumbing codes and ordinances.
2. Plumb brewer into water supply using ¼-inch copper tubing. Flush water line before installing brewer to remove sediment. Brewer should be connected to COLD WATER LINE for best operation.
3. Water pressure should be at least 20 lbs. Water line must supply a minimum of ½ GPM. For less than a 25 ft. run, use ¼" tubing and connect to ½" or larger water line. The inlet water fitting on the back of the brewer is a ¼" flare fitting.
4. If installed with saddle valve, the valve should have a minimum of ⅛" porthole for up to 25 ft. run, and ⅝" porthole for over 25 ft. runs.
5. Turn on water supply and check for leaks.

INITIAL SET UP

1. Open and install the grill into the drip tray. Place drip tray into waste bin.
2. Connect water fitting with strainer on the rear of machine next to the power switch.
3. Ensure power switch is in the off position ("O") and plug the machine into a properly installed and grounded electrical circuit.
4. Turn power switch to the on position ("I") to start the initial water fill cycle.

START UP AND USAGE

The display will show the current program version for a few seconds when initially turned on. As the tank fills, the display will show "Tank Filling", then it will change to "Heating"- allow up to 10 minutes for the tank to reach brewing temperature. When the tank has finished heating, you will be able to use your machine.

BREW OPERATION

1. Place cup under brew nozzle on drip tray.
2. Press "OPEN" button.
3. Unwrap the pod & place flat side up in center of brew chamber. *Do not pinch your pod.*
4. Press the desired brew button-chamber will close & brew cycle will start.
5. Once the pod drying cycle is complete, the pod will eject into the waste bin & the cup can be removed.

MACHINE PROGRAMMING

PROGRAMMING SETTINGS

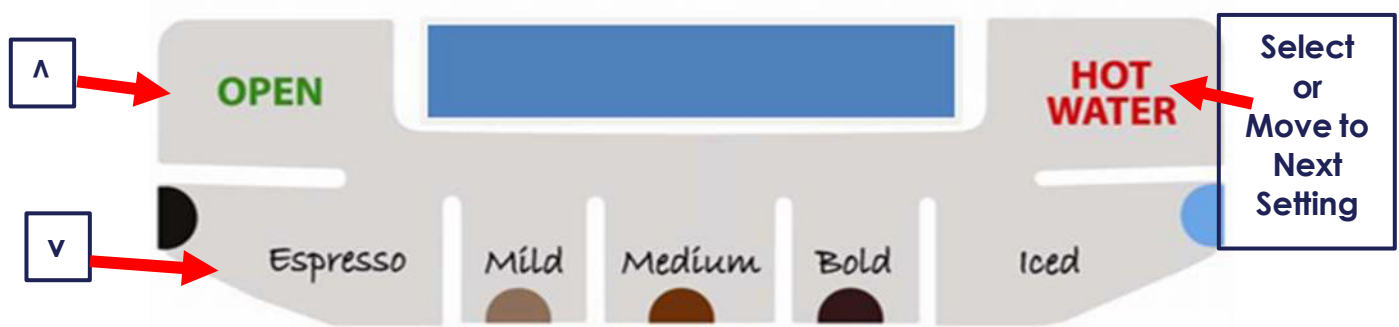

Fig 1: Fresh Cup Buttons

The Fresh Cup pod brewer has a menu that consists of scrolling menu entries that can be scanned through in any direction using the OPEN(^) and Espresso(v) buttons.

Note: the menu list does not loop back around.

To enter the Programming Menu, press and hold the Hot Water Button when powering up machine. There are eight entries in the Main menu and more in various sub menus. The entries in the Main Menu are as follows:

- **SET TEMPERATURE**
- **SET ENERGY SAVE MODE**
- **SET ENERGY SAVE TIME**
- **SET BUZZER VOLUME**
- **SET POD COUNT**
- **FLOWMETER ADJUSTMENT**
- **RECIPE SETTINGS**
- **SELECT WATER FILTER**
- **EXIT MENU**

With these entries, the OPEN (^) and Espresso (v) buttons will change the setting, incrementing or decrementing by one. Pressing Hot Water Button will select the entry shown on the screen. After changing the settings in the entry, pressing the Hot Water Button will exit, taking you to the next entry. When you are finished in the Settings Menu, scroll, using the OPEN button, to the Exit Menu entry. Press the Hot Water Button to exit the Programming Settings. This will save all of the changes at once, and machine will be ready to brew.

SET TEMPERATURE

In this entry the user may set the tank temperature in the range of 180°F to 203°F with the default at 200°F.

Higher Elevations: at 5000 ft, set the temperature to 195°F.

SET ENERGY SAVE MODE

This entry allows the user to select from three different power modes to conserve energy during periods of non-use.

OFF (DEFAULT)

No Energy Save, power on.

ENERGY SAVE

Partial Energy Save Mode. After the user selectable time out passes, the tank temperature set point is set to 180 until any interaction is detected.

FULL ENERGY SAVE

Full Energy Save Mode. After the user selectable time out passes, the tank heater is disabled until any interaction is detected.

Note: after 72 hours of non-use, the heater will turn off. Any interaction will turn the heater back on.

SET ENERGY SAVE TIME

This entry will not be displayed if the Energy Save function has been set to "OFF". This entry sets the time the machine will maintain temperature until the power save function is activated. The user can choose 1 through 4 hours in 1-hour increments with the default set to 4 hours.

SET BUZZER VOLUME

The range is from 0 to 100. The default is 20. You will hear the machine beep whenever a button is pressed.

SET POD COUNT

In this entry the user may set the number of pods the brewer will hold before signaling that the bin is full. The range is 10 to 100 pods, with the default at 50. This can be turned off, if you are using a special ordered pass through brewer. Standard waste bin capacity is 50 pods. The waste bin must be out of place for 10 seconds before the pod count is reset. *It is recommended that you empty and rinse the waste bin every day.*

TO REMOVE WASTE BIN

Gently pull on the sides of the silver base where the drip tray rests. Please note that the drip tray itself can be removed, and has two different height slots.

FLOWMETER ADJUSTMENT

Each increment of this setting adjusts the calibration of the volume of liquid dispensed by 0.2 ounces. This can be used to fine tune the amount of liquid that is dispensed.

Note: This setting will adjust all recipe volumes to provide precise accuracy.

THESE MACHINES ARE EQUIPPED WITH A FLOWMETER

Please run your Fresh Cup pod brewer a few times. Ensure volume dispensed is consistent, so that *no further calibration is needed*. Please note that running cycles without a pod will yield in approximately ¼ oz more than programmed dispense volume.

The flow adjustment is likely to be around +3 when coming from the factory. If this needs to be adjusted over time, then there could be an issue with hardwater buildup, or possibly a component failure- most likely the pump, or the flowmeter in this case.

This setting is only to fine tune dispensed volume. Please refer to Recipe Settings below to change the amount in whole ounces to be dispensed.

NOTE: The machine has been calibrated at the factory and has been adjusted to brew into an 8 ounce cup with approximately 7 ounces of coffee for brew strengths of mild, medium, and bold.

RECIPE SETTINGS

This entry allows you to program most buttons to the recipe of your choosing. All buttons except for the HOT WATER button are programmable.

When SELECT BREW BUTTON appears, press the button you wish to program. This will take you to the Button Set Up sub menu.

SET BREW VOLUME

This entry sets the volume in ounces for the chosen brew button to dispense. The range is from OFF/ 0.0 to 16.0 ounces with the default set to 7.0 ounces, with the exception of Iced and Espresso recipes. Setting the volume to OFF will disable the button.

SET PRE-INFUSION VOLUME

This entry sets the volume of the pre-infusion pulse of water in ounces. Range is 0.0 to 3.0 oz. Default varies by recipe drink strength.

SET COFFEE PUMP SPEED

In this entry the user may set the pump strength in the range of 10 to 100 with the default at 35.

Note: A high pump speed can negatively affect extraction and can be noisy. It is not recommended to change this setting.

SET AIR PUMP SPEED

In this entry the user may set the air pump strength in the range of 30% to 100% with the default at 80%. Please note that too high of a speed can result in a broken coffee pod.

SET AIR PUMP TIME

In this entry the user may set the air pump time in the range of 2 to 15 seconds with the default at 10 seconds.

SET BREW PULSE TIME

This entry sets the pulse time in seconds for a cup of coffee with on/off pulses. The range is from 0 to 30 seconds with the default varying by recipe drink strength.

Note: A longer pulse time results in a bolder brew.

Please note that we take our time to develop the default recipe parameters.

EXIT

Exit using Hot Water Button to SELECT BREW BUTTON. From there you can press the Hot Water Button to advance to the main programming menu.

WATER FILTER

The default setting is "OFF". If you are installing a purchased water filter, then set this to match the size of the filter. This machine can accommodate a filter size range of 500 gallons to 3000 gallons. This sets the counter for the filter warning. When ever water is dispensed, the counter is incremented to account for the water dispensed. When the counter is above 90% of the capacity of the chosen filter a warning message is displayed in place of the "READY" message. To reset the counter after installation, the user must enter the programming menu and enter the "RESET FILTER" entry described below. If the filter selection is "OFF" then following entries are not available.

GALLONS REMAINING

This entry shows the number of gallons left before the filter should be replaced.

RESET FILTER

Press and hold the Open button, timer will count down to reset the counter

EXIT MENU

Exit with Hot Water Button and begin brewing.

FACTORY SETTINGS

This is accessed by holding the Iced button down while machine is powering up.

BREW CYCLES

This is a non-resettable count that displays the number of brew cycles the machine has dispensed.

RESET FACTORY DEFAULTS

This feature will reset every single setting. This includes flowmeter adjustment and all recipe settings.

DRAIN WATER LINES

This program drains water currently inside of the machine tubing. Note that draining the water tank is separate, and is done manually. Draining the lines takes just under 1 minute. From this selection, follow these steps:

1. Turn off water and disconnect from water line.
2. Drain tank. See page 16.
3. Press the "Hot Water Button" button to run the draining program.

Make sure you have a container in place to catch any water that may be in the water lines inside the machine.

FLOWMETER TEST

This is a diagnostics test. It is likely only to be run when on the phone with a servicer. Before running this test, ensure you have a way to accurately measure the number of ounces dispensed. The test takes a total of about 45 seconds, water will pulse through the machine several times, with corresponding numbers showing up on the screen. Servicers will only need the last number.

Flowmeter math: The number on the screen is the number of rotations the flowmeter counted. Multiply this number by 0.042 to calculate the number of ounces delivered. This should match the measured number of ounces dispensed.

EXIT

Exits Factory Settings to begin brewing.

MACHINE OPERATION

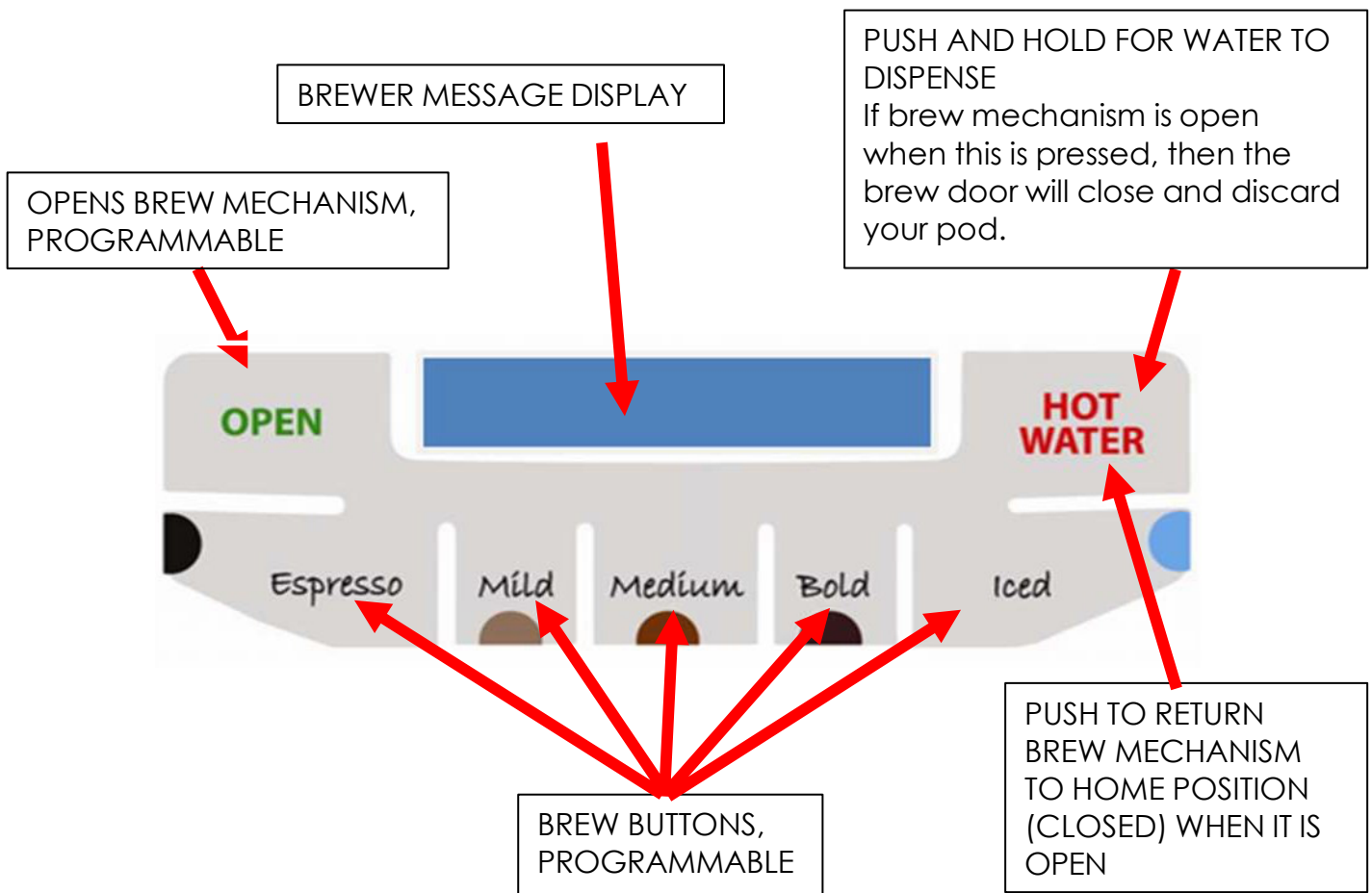

Note: Pressing any button during a brew cycle will cancel the brew

BREW OPERATION

1. Place cup under brew nozzle on drip tray.
2. Press "OPEN" button.
3. Unwrap the pod & place flat side up in center of brew chamber. *Do not pinch your pod.*
4. Press the desired brew button-chamber will close & brew cycle will start.
5. Once the pod drying cycle is complete, the pod will eject into the waste bin & the cup can be removed.

SERVICING THE MACHINE

The Fresh Cup machine has a hot water tank assembly and brew mechanism. These assemblies can be easily removed from the machine.

SIDE PANEL REMOVAL

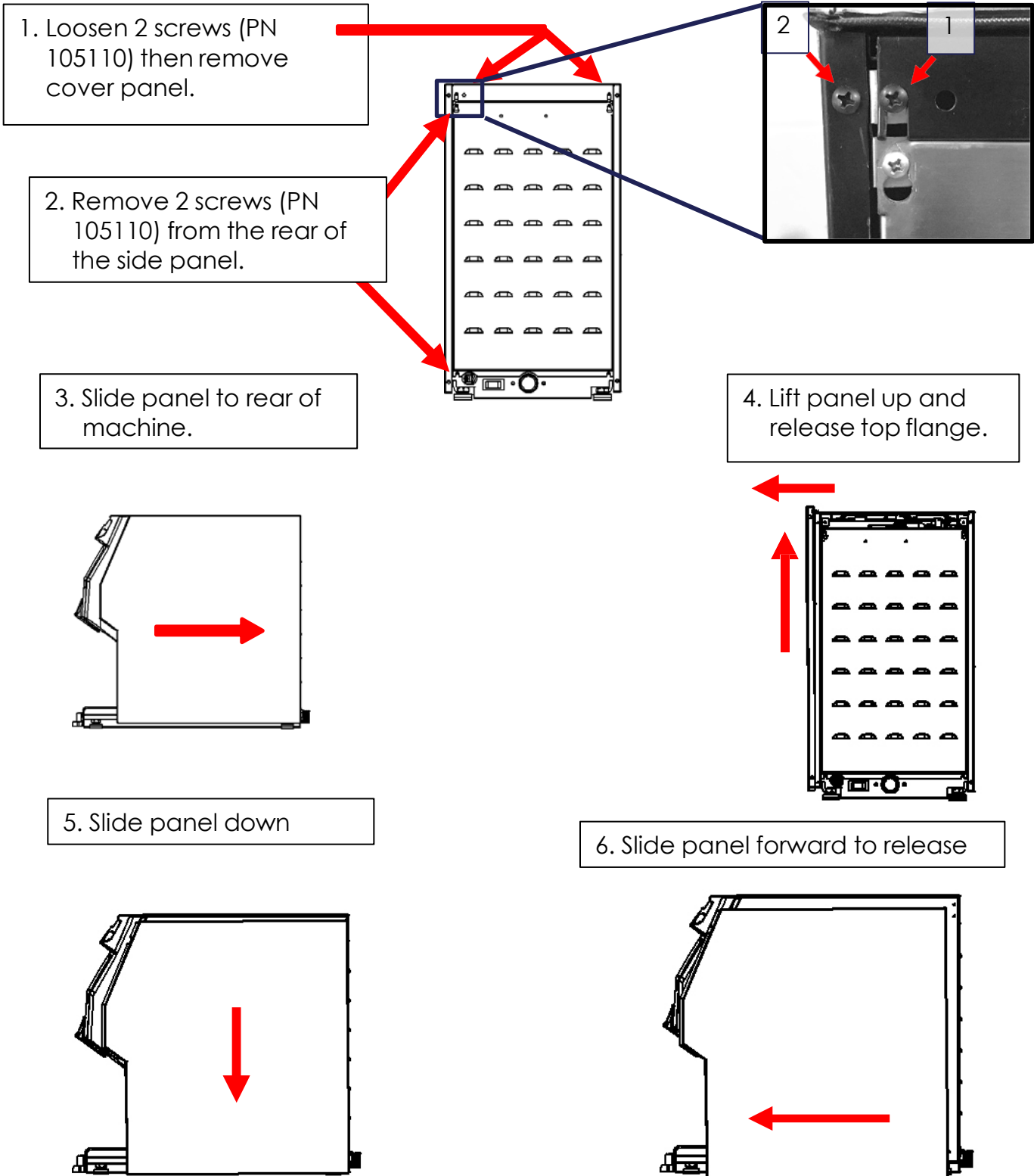

REMOVING THE BREW MECHANISM

Remove brass knurled nuts (PN 700021). Be sure you do not lose the washer.



Next, disconnect the water connection, and the harness connection.



Note: Shipping Support Bracket must be removed

DRAINING THE HOT WATER TANK

Tank holds approximately 1 US gallon.

Caution- The water is extremely hot and can cause harmful burns, unless the hot water tank is left to cool. Do not store in freezing conditions as residual water may remain in machine.

METHOD 1

TO DRAIN

1. Unplug machine and remove waste bin. Allow machine to cool before proceeding.
2. Reaching up into the machine from where the waste bin sits, locate the tube clip on the left side of the opening. Follow the tube up to locate the drain tube bracket. See Image 1.
3. Push the tubing up to release it from the bracket. You may need to follow the bracket to the right and push up on the tube from the right side to fully release the drain tube.
4. Pull the tubing down and out to the front of the machine.
5. Remove the tube plug using pliers, then aim end of tube to where you are draining the water. Push up on tube clip to open tube. See Image 2.

TO REPLACE

1. Once the tank is fully drained, tighten the tube clip and insert the drain plug
2. Feed the tube back up into machine, starting from right side of the tubing.
3. Locate the tubing bracket and line tube up with bracket.
4. Using your fingertips, press on the tube and roll it down into the bracket until secure.
5. Ensure tube clip is tucked away on the left side of the tank plate so that it does not interfere with brewing mechanism.

METHOD 2

TO DRAIN

1. Unplug machine and remove waste bin. Allow machine to cool before proceeding.
2. Remove top cover of machine. See page 17.
3. Locate drain tube and drain tube bracket. See Image 1.
4. Starting on the left side, pull drain tube up out of the bracket. Once free, feed the drain tube down and out to the front of the machine.
5. Remove the tube plug using pliers, then aim end of tube to where you are draining the water. Push up on tube clip to open tube. See Image 2.

TO REPLACE

1. Once the tank is fully drained, tighten the tube clip and insert the drain plug.
2. Feed the tube back up to top of machine, starting from right side of the tubing.
3. Line the tubing up with the drain tube bracket, then, starting on the right side, push and roll down to secure tubing into bracket.
4. Ensure tube clip is tucked away on the left side of the tank plate so that it does not interfere with brewing mechanism.
5. Replace top cover of machine.

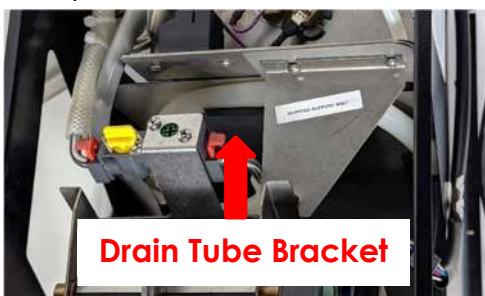

Image 1

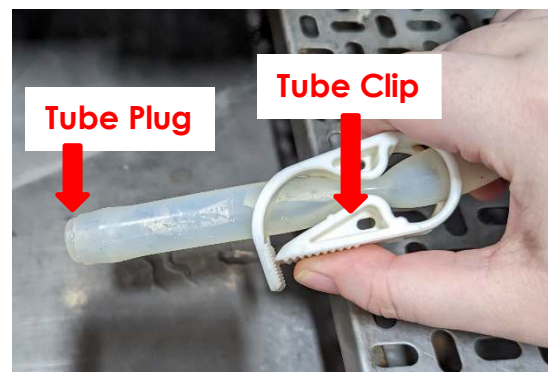

Image 2

TANK REMOVAL & ACCESS AREAS

Note: top cover must be removed before removing side panels.

TANK REMOVAL

1. Remove top cover by loosening 2 screws (PN 105110), then remove back cover by loosening 4 screws (PN 102333)

2. Remove 2 different nuts (PN107069 near rear and PN107240 near front).

3. Loosen 2 screws (PN 105043) then push down to release shipping bracket

Side Panel Top Cover

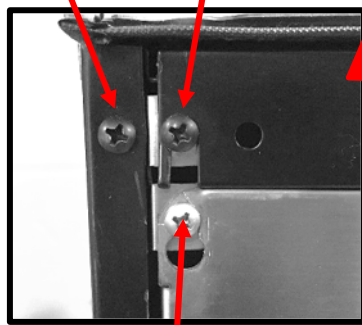

Back Cover

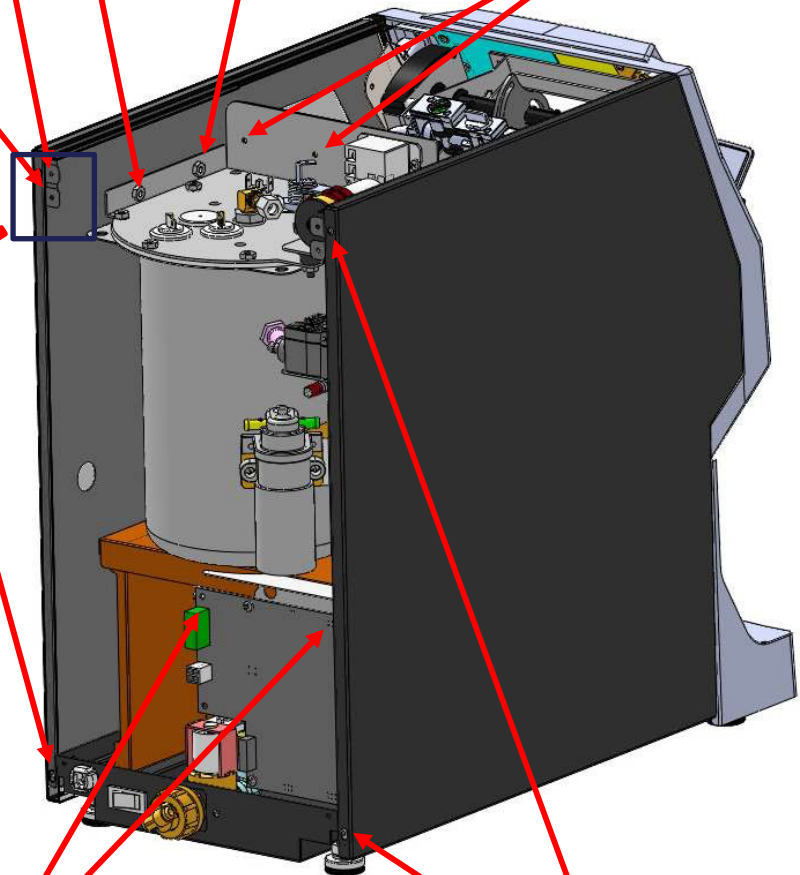

Loosen but do not remove these two screws (PN105048), then lift and pull control board & bracket out of the machine to access transformer.

Remove two screws (PN105110) to remove side panel for pump access.

ERROR MESSAGES

"CONTACT/SERVICE" LWR/UPR THERM

Thermistor is open or shorted. Make sure thermistor is connected properly. If connected, replace PN 151677. If this error returns, there is likely a circuit board failure.

"CONTACT/SERVICE" OVERHEAT

Machine detects a temperature of over 210°F. This will prompt the machine to turn off the heater.

"CONTACT SERVICE" CHECK HEATER

Water is not heating up at expected rate- at least 1°F rise in temperature over 4 minutes, or heater has been running continuously for 30 minutes. Check Hi Limit Thermostat (PN 111593), then check heating element (PN 704166 for US 1700W or 704161 for Canada 1400 W), lastly check heater relay (PN 110958).

"CONTACT/SERVICE" TOP/BTM BREW MOTOR OPEN

Brew chamber drive motor error- check for jam or obstruction in brew chamber.

"CONTACT/SERVICE" CHECK WATER

Tank fill error- water level not reaching probe in a timely manner. Check for water supply for disconnections or leaks.

NOTE: Due to large tank capacity, fill time out error may occur on startup. Please turn machine off, and then back on to clear the error and continue filling.

"CONTACT/SERVICE" FLOWMETER ERROR

Possible pump, flowmeter, or circuit board error. Check water and harness connections at the flowmeter. Check flowmeter harness connection at the control board.

INSIDE YOUR MACHINE

UNIVERSAL 2 POD BREWING MECHANISM

780585

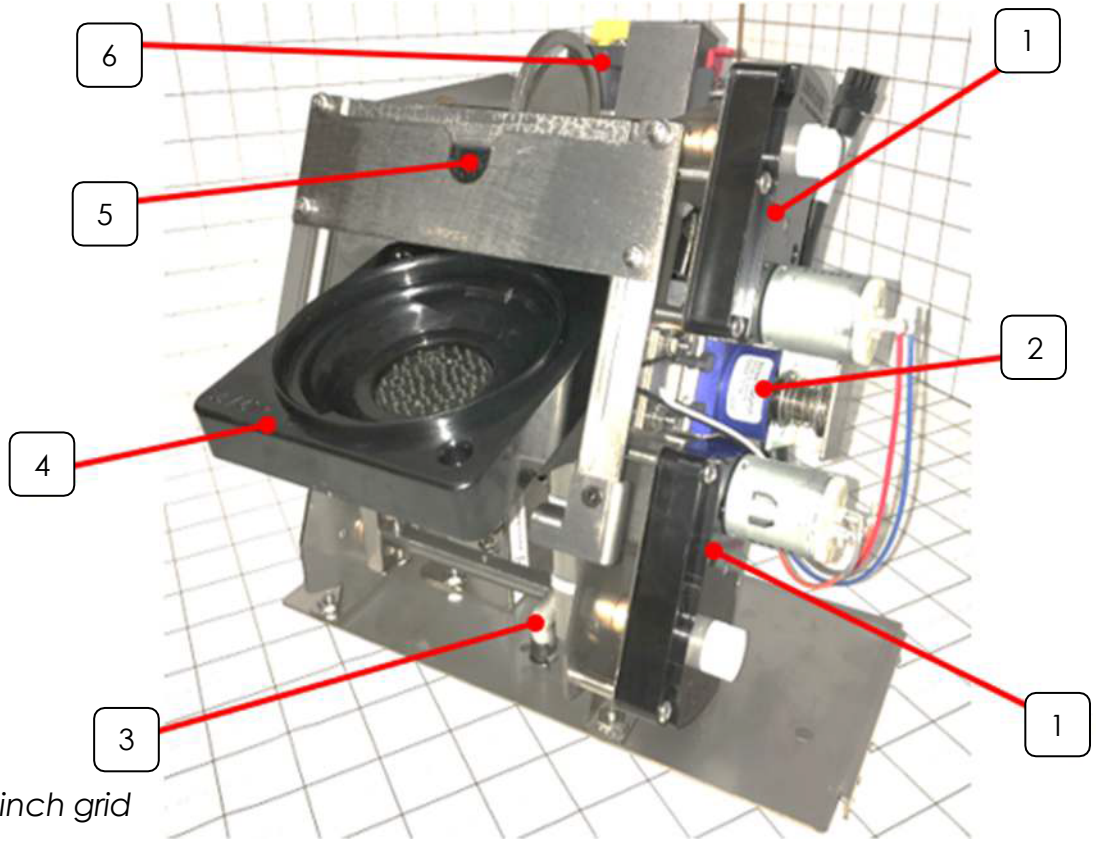

Picture taken on a 1 inch grid

ITEM	PART NUMBER	DESCRIPTION	QTY
1	780230	BREW MECH MOTOR	2
2	780231	DELTROL SOLENOID	1
3	780368 & 780320	BREW HOSE WITH PROTECTIVE SPRING	1
4	780871	LOWER BREW CHAMBER UNIVERSAL 2 ASSEMBLY	1
		6-32 SCREWS	
		O-RING	
		1/4" X 1" STANDOFF SPACER	
		COMPRESSION SPRING	
		CUP WASHER	
		DISC ASSY, MOLD, 13 HOLE	
		MOLDED BUMP DISC PAD	
		LOWER BREW CHAMBER	
5	780775	UPPER BREW CHAMBER ASSEMBLY	1
	773246	U-CUP SEAL	
		UPPER BREW CHAMBER	
6	320043	VALVE WITH SHOUT OFF	1

Newco has many replacement kits available.

NOTE: Your machine can be equipped with various optional brew mechanisms to provide brewing choices tailored to your specific needs. For information on these optional brew mechanisms and associated replacement parts contact NEWCO Technical Services at 1-800-556-3926 or NEWCO Customer Service at 1-800-325-7867

TANK ASSEMBLY 780619

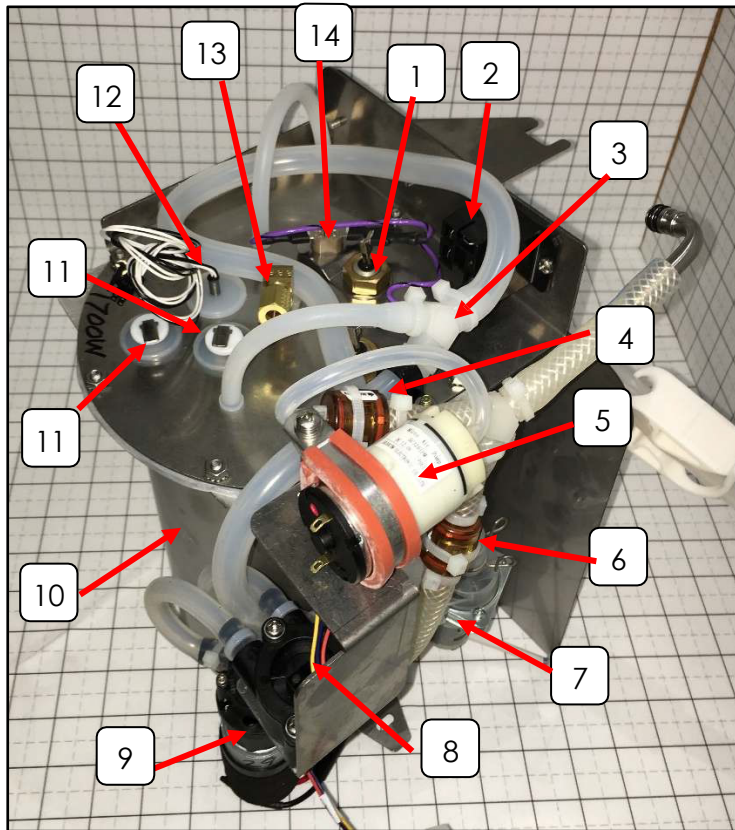

783371 (ALTERNATE)

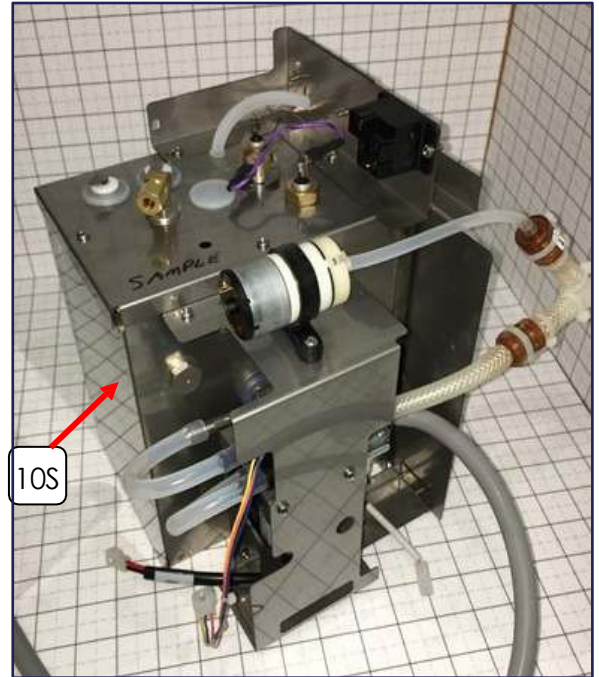

NOTE: Due to large tank capacity, fill time out error may occur on startup. Please turn machine off, and then back on to clear the error and continue filling

ITEM	PART NUMBER	DESCRIPTION	QTY
1	704166 (1700W)	TANK HEATING ELEMENT (US)	1
	704161 (1400W)	TANK HEATING ELEMENT (CAN)	1
2	110958	RELAY, 12 VDC SPST 30A	1
3	767281	"Y" HOSE FITTING	1
	780090	AIR PUMP KIT	1
4	202165	CHECK VALVE ASSEMBLY	
	773056	AIR PUMP	
6	202178	WATER PUMP CHECK VALVE	1
7	781772	PUMP ASSEMBLY W/ELBOW (HOT WATER)	1
8	120682	DEFOND FLOWMETER	1
9	109937	GEAR PUMP ASSEMBLY	1
10	780253	ROUND TANK	1
	780647	TANK LID ASSEMBLY ASSEMBLY (ROUND)	
	704221	TANK GASKET (ROUND TANK)	1
10S	783372	SQUARE TANK ONLY	1
	783377	TANK LID ASSEMBLY (SQUARE)	
	119882	TANK GASKET (SQUARE)	
11	500384	PROBE KIT 1.818"	2
	151677	DUAL TEMP THERM PROBE	1
13	100149	ELBOW 1/4 C x 1/8 NPT	1
14	111592	HI-LIMIT THERMOSTAT	1

ELECTRICAL COMPONENTS

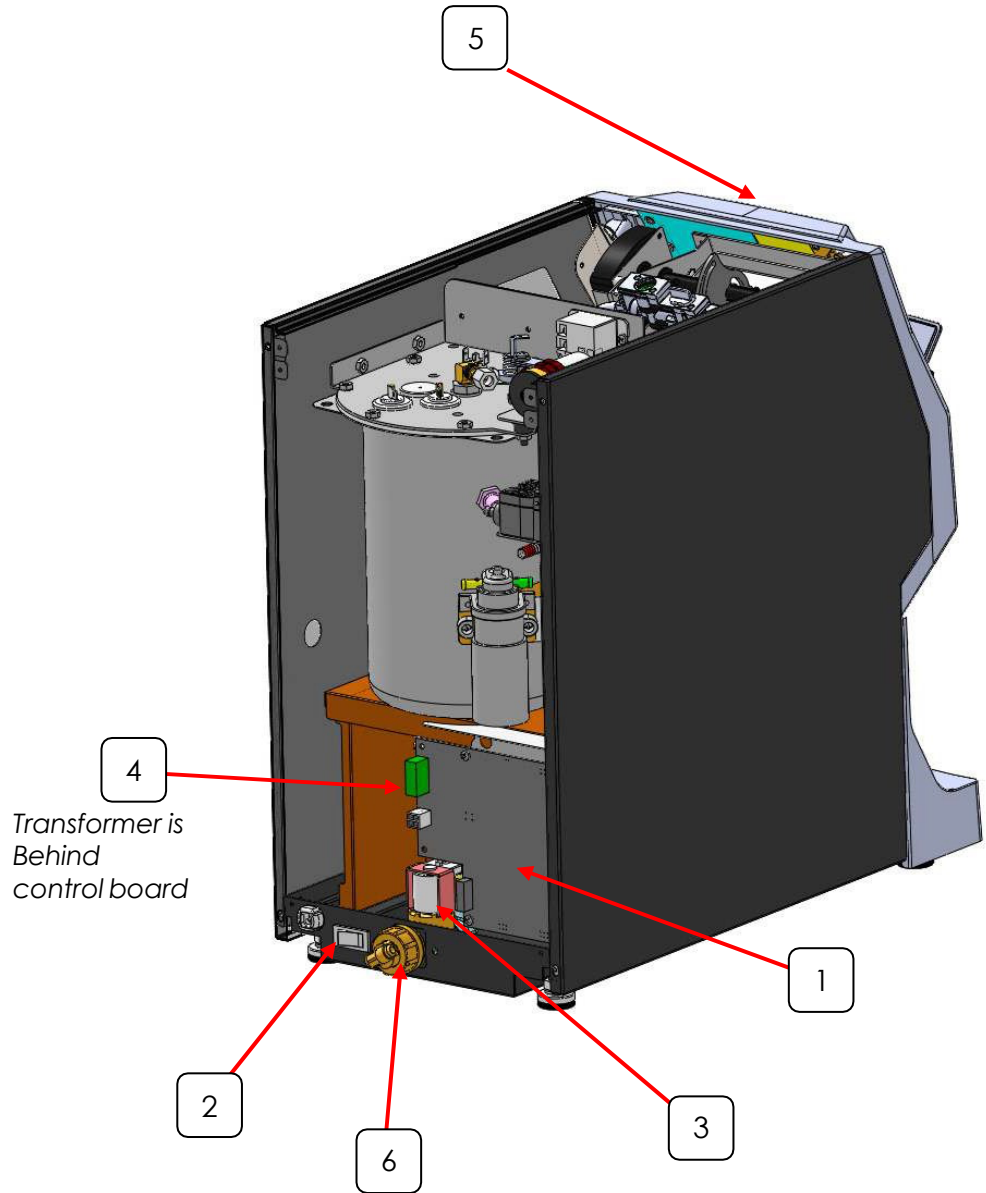

ITEM	PART NUMBER	DESCRIPTION	QTY
1	782187	CONTROL BOARD & BRACKET	1
2	110626	SWITCH, DPST, ON/OFF	1
3	780381	SOLENOID FILL VALVE	1
4	105115	TRANSFORMER 120VAC-24VAC	1
5	780601	DISPLAY BOARD	1
6	111775	INLET ASSEMBLY	1

WIRING DIAGRAM

Wire colors may change based on availability.

